

14 WATT HIGH FIDELITY POWER AMPLIFIER

MODEL

HF-14

77-11



EICO

INSTRUCTION

MANUAL

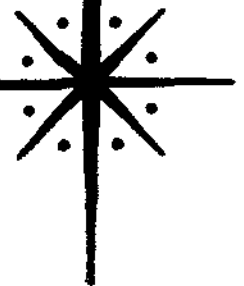

ELECTRONIC INSTRUMENT CO. INC.
3300 NORTHERN BLVD., L. I. CITY 1, N. Y.



*Electronics Hobby Shop
Turner A. F. B., Ga.
etc. David W. Baldwin, Miss.*

general description

GENERAL

The EICO HF-14 is a 14 watt high fidelity basic power amplifier employing two EL84 output tubes in push-pull and a high quality output transformer. The high power sensitivity of these remarkably fine tubes eliminates the necessity for additional driver stages, permitting the use of a large amount of inverse feedback with a high stability margin. The lower operating voltages required and the use of EZ81 rectifier tube having a warm-up characteristic exactly matched to the output tubes, result in a power supply of exceptional reliability as well as extended output tube life. Filter electrolytics and the rectifier operate well below maximum ratings and voltage surges at starting are eliminated.

The HF-14 has been designed to maintain its excellent

characteristics under speaker load (including electrostatic types) as well as the resistive load normally used for testing. Phase corrections have been provided at both extremes of the audio spectrum to insure stability under all conceivable conditions and to insure that variations in components and construction will not affect the performance. Stability is maintained on all speaker taps with loads ranging from zero to infinity. Overload characteristics are excellent and the HF-14 will not exhibit bounce or flutter under pulsed conditions.

The HF-14 can be operated from any preamplifier control unit. A power take-off socket is provided for powering the EICO HF-65A or HF-61A preamplifier control. Other features include a panel mount fuse holder, switched and unswitched convenience outlets, and heavy gauge cadmium plated steel chassis finished in baked enamel.

SPECIFICATIONS

Rated Output Power: 14 watts continuous, 28 watts peak.

IM Distortion (60 cps & 7 kc at 4:1): 1.7% at 14 watts, 0.33% at 26 watts, 0.1% at 4 watts.

Harmonic Distortion: 8 watts less than 1% from 30 c to 10 kc.
10 watts: less than 1% from 40 c to 10 kc.
14 watts: less than 1% from 50 c to 5 kc.
20 c distortion: 2% at 4.2 watts.

Transient Response: excellent square wave reproduction (4 usec rise time); negligible ringing, rapid settling on 10 kc square wave.

Inverse Feedback: 20 db

Stability Margin: 12 db

Damping Factor: above 8, 20 cps to 20 kc.

Sensitivity: 1.25 volts for 12 watts output.

Hum: 90 db below rated output

Speaker Connections: 4, 8, and 16 ohms.

Tubes: 1- ECC83/T2AX7, 2- EL84, 1- EZ81

Power Source: 117 volts, 60 cps.

Power Consumption: 65 watts

Size: HWD: 3 3/4" x 12" x 4".

Shipping Weight: 10 lbs.

mechanical installation

GENERAL

a) **HEAT DISSIPATION (VENTILATION):** In common with other electronic equipment, the Model HF-14 produces a great deal of heat in normal operation. Unless continuous and adequate air flow is obtained around the heat producing elements, these elements will overheat and their useful life will be greatly curtailed. Adequate ventilation will be provided if the amplifier is installed in an open-back console provided that the top of the amplifier is spaced at least two inches below any shelf mounted above it. If the cabinet is enclosed at the rear, provide several large holes or slots as low down and as high up in the cabinet back as possible. As an alternate, holes may be provided in the sides, bottom, or top of the cabinet. The important thing to remember is that effective ventilation requires provision for cool air to enter at the bottom and to leave at the top.

If the amplifier is not installed in a console, it should be situated preferably on an open surface. An attractively finished matching cover for the Model HF-14 is available which will provide a "finished" appearance as well as protection when the amplifier is not installed in a console. Four rubber feet are also provided so that the amplifier will not mar the surface of furniture on which it is placed.

b) **ACCESSIBILITY TO PARTS:** Tubes are the most frequently replaced items in electronic equipment. If the amplifier is placed in a console, sufficient space should be allotted to reach and remove any tube in the amplifier. Furthermore, input and output terminals of the amplifier should be accessible to permit easy interchanging of system components for comparison. If antennas are strung around the back of the console in which the amplifier is installed, arrange them so they will not interfere.

c) **ELECTRICAL ISOLATION:** To realize the full benefit of having a power amplifier physically separate from the preamplifier-control unit and/or tuner, the power amplifier should be placed at least one foot away (more if possible) from either or both of these units.

d) **ACOUSTICAL ISOLATION:** If amplifier and speaker are installed in the same cabinet, provide sufficient separation to minimize mechanical speaker vibration reaching the amplifier. The minimum separation is about one foot.

CONSOLE MOUNTING

Having determined a proper location for the amplifier in the particular console, the correct procedure for mounting the amplifier chassis is as follows: a) If the rubber feet have been inserted in the bottom plate, remove them (pry out with a thin screwdriver). b) Remove the 6 screws which fasten the bottom plate to the chassis. c) Place the bottom plate (bumps facing up) at the location on the shelf or other mounting surface in which it is desired to mount the amplifier. With a sharp pencil, placed with its point directly against the edge of the lower surface of the bottom plate, draw the outline of the bottom plate on the shelf and also mark the positions of the four outer holes. d) Remove the bottom plate and drill each of the marked holes on the shelf to a diameter of 1/4". e) Refasten the bottom plate to the chassis, with 2 #8 x 3/8 screws previously removed, using the holes at the center. f) Replace the chassis on the shelf, positioning it exactly in the outline previously drawn. g) From the bottom side of the shelf, insert a #8 x 1" screw with a 1/2" flat washer against the head through each of the four holes. These screws engage the stamped nut over each hole in the chassis flange and when tightened secure the chassis to the shelf.

electrical installation

POWER

A) **POWER REQUIREMENTS:** The EICO Model HF-14 requires 65 watts at 110 to 120 volts, 60 cycles AC.

b) **REMOTE SWITCHING:** The EICO Model HF-14, although not provided with its own ON-OFF power switch, has provision for remote switching, through an octal socket mounted on the chassis. Pins 6 and 7 of the octal socket are internally connected to the ends of a break in one power transformer primary lead and are externally connected together by a jumper in a male octal plug inserted in the octal socket. When this male plug is removed, pins 6 and 7 may be brought out to an external AC switch, usually in a preamplifier unit. This is one of the connection functions accomplished with the octal plug-and-cable attached to the EICO HF-65A and HF-61A preamplifier-control unit. If the HF-14 power amplifier is being used with a self-powered tuner-preamplifier, the octal fur-

nished with the HF-14 remains inserted in the octal socket (to connect the primary of the power transformer to the AC line and to ground one side of the filament winding) and the line cord of the HF-14 is inserted in a switched 117VAC convenience outlet in the control unit. Note: When using a self-powered preamplifier-control unit, touch one end of a wire to the preamplifier chassis and the other end at the power amplifier chassis. If a spark occurs, remove the HF-14 line cord plug and re-insert it with the prongs reversed.

a) **POWERING AUXILIARY PREAMPLIFIER:** The same octal socket provides all necessary filament and B+ voltages for operating an auxiliary preamplifier-control unit. 6.3 volts AC filament voltage, at 1 ampere, may be obtained from pins 1 and 2; pin number 4 on the socket supplies 350 volts DC, at a maximum current of 10 milliamperes; and pin 3 is connected to ground. As stated above, control of 117 volts AC line power to the power

amplifier, and indirectly, power for the preamplifier-control unit, itself, is made available through the connections to pins 6 and 7. This arrangement is exactly suitable for powering the EICO HF-65A and HF-61A preamplifier-control unit; all that need be done is to remove the octal plug provided with the HF-14 from the octal socket and insert the octal plug-and-cable of the HF-65A in its stead. Note that a jumper between pins 2 and 3 of the octal plug furnished with the HF-14 effectively grounds one side of the filament winding; removal of the octal plug leaves the filament winding floating. This arrangement is used because a hum balance control is connected across the filament leads in the EICO HF-65A preamplifier and the arm of this control is returned to ground.

d) **CONVENIENCE OUTLETS:** When the HF-14 is used with a preamplifier that takes power from it, such as the EICO HF-65A, the convenience outlets of the HF-14 will be found useful. The outlet marked "117VAC SW." ("SW." is an abbreviation for "SWITCHED") is "live" or "dead" depending on whether the preamplifier power switch is turned to ON or OFF; plug tuners into the outlet. The outlet marked "117VAC" is not switched and is "live" whenever the HF-14 line cord plug is inserted in a wall outlet; plug a record changer into this outlet in order to protect the mechanism. When the HF-14 is used with a self-powered preamplifier, such as the EICO HF-65A, normally the convenience outlets on the preamplifier will be used. However, the HF-14 outlets may be used also, if desired, in which case both of them will be "switched".

INTERCONNECTION OF COMPONENTS: SIGNAL

a) **PREAMPLIFIER-CONTROL TO POWER AMPLIFIER:** Single conductor, shielded cable must be used to interconnect the preamplifier-control unit or tuner-preamplifier-control unit and the power amplifier. Unless the source has a low impedance outlet, such as a cathode follower (with which up to 50ft. of cable can be used), use the shortest possible connection; in any case, use a low capacity type of shielded cable (as low as 25 mmf capacity per foot is available). Both ends of the cable must be fitted with RCA type phono plug connectors.

b) **SPEAKER CONNECTIONS:** To connect your speaker to the amplifier properly, you must know its rated impedance, which is usually marked on the speaker or specified in the manufacturer's literature. Connect one speaker lead to the terminal on the rear apron marked "G" and the other speaker lead to the nearby terminal designated by the rated speaker impedance (4, 8 or 16 ohms). Plastic-covered lamp cord may be used for distances up to 50ft. with little power loss. For shorter distances, tv antenna lead can be used, particularly if it is desired to run the speaker lead under a rug.

If it is desired to use two similar or identical full-range speakers of the same rated impedance (either 8 or 16 ohms only) for better sound distribution, connect one speaker lead of each pair to "G" and the two remaining leads to

the terminal with a number equal to half of one of the speaker's rated impedance. (It may be necessary to "phase" the two speakers by reversing both of the leads from one of the speakers.) This may not be done if each of the speakers is designed for reproduction of a different part of the audio spectrum (woofer-tweeter combinations), in which case a cross-over network is required which connects to the amplifier with only one pair of leads.

INTERCONNECTION PROCEDURE

a) Make all system interconnections before applying AC power. Making or breaking interconnections while AC power is applied will result in a momentary overload of both the power amplifier and speaker system with possible damage to either or both.

b) If the EICO HF-65A preamplifier control unit (not self-powered) has been obtained in kit form, remove all the jumper connections in the octal plug supplied with the HF-14 and wire the preamplifier power take-off leads to this plug as follows:

Color of Preamp. Lead	Pin of Octal Plug Connected to
grey	6
grey	7
brown	1
brown	2
red	4
black	3

Wired HF-65A preamplifiers will have the preamplifier leads connected to the octal plug as in the table above.

c) If it is desired to use a preamplifier without a power supply other than the HF-61A or HF-65A, the power take-off leads of the preamplifier should be connected to the HF-14 octal plug (after removing the jumpers) as follows:

Preamp. Power Lead	Pin of Octal Plug Connected to
AC ON-OFF	6
AC ON-OFF	7
filament (6.3 VAC)	1
filament (6.3 VAC)	2
B+	4 or 5*
ground	3

* If the preamplifier requires 350VDC, use pin 4; if the preamplifier requires less than 350 VDC, use pin 5 and connect a dropping resistor of appropriate value and voltage rating from pin 4 to pin 5 of the octal sockets on the HF-14 chassis. For example, if the preamplifier in question requires 300 VDC B+ voltage at 10 ma drain, the dropping resistor will be required to drop the voltage by 50 volts (350-300 = 50) at a current of 10 ma. By Ohm's Law, the required resistance in ohms is the voltage drop in volts divided by the current in amperes or 50 volts/.01 amp. = 5000 ohms. The power dissipated in the resistor in watts is equal to the voltage drop in volts multiplied by the current in amperes or 50 volts x .01 amp = 0.5 watts. For safety a resistor of double the wattage rating should be used. Therefore, a 5000 ohm 1 watt resistor is required.

maintenance

CONTROL ADJUSTMENTS

a) The INPUT LEVEL ADJ. control is intended to protect the speaker system from "blasting" should someone turn the preamplifier-control unit level controls to full, by permitting you to attenuate the preamplifier output signal by any desired amount at the input to the power amplifier where it can not be "fiddled" with. Start by setting the INPUT LEVEL maximum counter-clockwise (maximum attenuation), using a screwdriver. Set the LOUDNESS control on your preamplifier to the maximum clockwise position and the LEVEL control at the midpoint of its range of rotation. Turn your phonograph on and play on average orchestral record. Then slowly rotate the INPUT LEVEL ADJ. control clockwise until the music is at normal (or concert) listening level. This completes the adjustment, which need not be repeated.

b) ON-OFF SWITCH: Should be used in ON position when unit is used with a preamplifier. It may be used as a power on-off switch when the amplifier is accessible.

TROUBLE-SHOOTING PROCEDURES

Your amplifiers should require little service except for normal tube replacement. We recommend no substitutions for the tube types used in this amplifier. The EL84, and EZ81 types are distributed nationally by the Ampere Electronic Corporation (230 Duffy Ave., Hicksville, L.I., N.Y.) and Mullard Ltd. (International Electronics Corp., 81 Spring St., N.Y. 12, N.Y.) If necessary, replacements can be obtained directly from EICO.

To facilitate servicing, remedial and trouble-shooting procedures have been provided in the TROUBLE SHOOTING CHART that follows. A VOLTAGE AND RESISTANCE CHART is also provided as an aid in locating defective components and to permit a careful, stage-by-stage check of the amplifier. DC operating voltages are given both at no signal and at a signal developing 14 watts output as well as the corresponding 1 kc signal voltages.

To isolate the source of unusual hum or noise in your system, first turn off the AC power and then unplug the audio cable connecting to the amplifier input. Then turn the AC power on again and note whether hum or noise has decreased. If it has, the fault is in the preamplifier or associated equipment and measures should be taken to correct it as described in the service notes for these units. If it is desired to provide a good building ground for your entire system, run a lead from under speaker connection terminal "G" to a cold water pipe. Do not connect such a ground wire to other components in the system.

If the trouble is no output or low output and the amplifier is suspected, check AC signal voltages starting at the in-

put and working step-by-step toward the output, using a sine-wave audio signal generator and a VTVM. Set the input signal to 1 volt. The corresponding grid and plate signal voltages for this input are indicated on the schematic diagram. This procedure should suffice to localize the defective stage.

If the trouble is an excessively distorted output, try tube replacement, signal tracing or proceed directly to voltage and resistance measurements.

When the defective stage is localized, proceed to a resistance and voltage check of the stage, using the data in the Resistance and Voltage chart. Disconnect the amplifier from the power line and discharge capacitors prior to making any resistance check or removing the EL84 output tubes. Do not turn the amplifier on with any of the output tubes removed.

CHECKING A TYPICAL TUBE STAGE

1. Check tube.
2. Check plate and cathode resistors.
3. Check coupling capacitors for leakage or short.
4. For output stage, check dc resistance of transformer windings.
5. Check grid leak resistor for open.
6. Check cathode by-pass capacitors for short.
7. If no or low B+ voltage on tube, check decoupling path for open or defective R14, and filter capacitor, C8 for short.
8. If wiring and circuit components including the tube check O.K. and B+ voltage is excessive, check the decoupling path for short or defective R14.

SERVICE

If trouble develops in your instrument which you can not remedy yourself, write to our service department listing all possible indications that might be helpful. If desired you may return the instrument to our factory where it will be placed in operating condition for \$5.00 plus the cost of parts replaced due to their being damaged in the course of construction. NOTE: Before returning this unit, be sure all parts are securely mounted. Attach a tag to the instrument, giving your home address and the trouble with the unit. Pack very carefully in a rugged container, using sufficient packing material (cotton, shredded newspaper, or excelsior), to make the unit completely immovable within the container. The original shipping carton is satisfactory, providing the original inserts are used or sufficient packing material inserted to keep the instrument immovable. Ship by prepaid Railway Express, if possible, to Electronic Instrument Co., Inc., 33-00 Northern Blvd., Long Island City 1, New York. Return shipment will be made by express collect. Note that a carrier cannot be held liable for damages in transit if packing IN HIS OPINION, is insufficient.

VOLTAGE AND RESISTANCE CHART

TUBE	PIN ^o	DC VOLTS NO SIGNAL	DC VOLTS 14 WATTS	AC VOLTS (1 kc) 1.25 VOLTS INPUT	RESISTANCE UNIT OFF
6CC05/12AX7 V1	1	105	102	10	600KΩ
	2	0	0	1.25	510KΩ
	3	0.9	0.9	1.13	1.8KΩ
	4 & 5	filament (6.3 VAC to pin 9)			-
	6	222	215	9.5	120KΩ
	7	112	105	10	600KΩ
	8	105	102	9.5	100KΩ
	9	filament			-
	6L84 V2, V3	1	0	0	9.5
2		0	0	9.5	340KΩ
3		12.5	15	.1	165Ω
4 & 5		filament (6.3 VAC between)			-
6		-	-	-	-
7		335	320	6	160-200Ω
8		0	0	9.5	330KΩ
9		340	325	182	0
6Z81 V4		1	-	-	295
	2	-	-	-	-
	3	340	325	-	160KΩ
	4 & 5	filament (6.3 VAC between)			-
	6	-	-	-	-
	7	-	-	295	95Ω
	8	-	-	-	-
	9	-	-	-	-

All voltages and resistances are measured to chassis. Voltages are measured with a high input impedance VTVM. All resistance measurements are made with pin 3 of the 6Z81 grounded except, of course, when the resistance to ground at pins 2 and 8 of the 6Z81 is being checked. Operating line voltage at which voltage measurements are made is 117 volts AC, 60 cps. NOTE: ALL VOLTAGE & RESISTANCE VALUES MAY VARY NORMALLY BY ±15%.

TROUBLE-SHOOTING CHART

SYMPTOM	CAUSE	REMEDY
House power line fuse blows; fuse, F1, remains intact.	Short in line cord, J2, J3 or associated equipment plugged into J2 or J3.	Repair
Fuse, F1, blows.	If the amplifier causes a replacement fuse to blow with rectifier tube V4 removed, primary or high voltage secondary windings of T2 are incorrectly wired or shorted. If F1 does not blow after replacement (with V4 removed), check for short in B+ circuits, defective V4 and C8.	Check and repair or replace. Check and repair or replace.
Any or all tube filaments not lit.	Open lead from 6.3 V winding of T2. 6.3 V winding of T2 open	Repair Replace T2.
DC voltage at V4 cathode (pin 3) is incorrect as specified below.		
a) No voltage	Defective V4. C8 shorted internally or externally. Connection to C8 broken.	Replace Replace or repair. Repair
b) High voltage	Connection to center tap of h. v. sec. winding of T2 open. Output tubes V2 and V3 over-biased or not drawing current.	Repair See trouble-shooting typical stage.
c) Low voltage	Excessive current drain in amplifier. Defective V4.	See trouble-shooting typical stage. Replace

REPLACEMENT PARTS LIST

<u>Stock #</u>	<u>Sym.</u>	<u>Description</u>	<u>Am't.</u>	<u>Stock #</u>	<u>Sym.</u>	<u>Description</u>	<u>Am't.</u>
22529	C1	cap., disc., 150mf, ±10%	1	97025	XV2, 3, 4	socket, 9 pin, bottom mount	3
22517	C2, 5	cap., disc., .025mfd - 500V (25K or 25,000)	2	40000		nut, hex, #6-32	12
22539	C3, 4	cap., disc., 200mf, ±10%	2	40001		nut, hex, 3/8-32	1
23007	C6	cap., elec., 50mfd - 25V	1	40007		nut, hex, #4-40	10
22533	C7	cap., disc., 47mf, ±10%	1	40008		nut, hex, #8-32	8
24011	C8	cap., elec., 30-20-20mfd - 450V	1	40016		nut, for fuseholder	1
20043	C9	cap., paper, .03mfd - 600V	1	40017		nut, tin., #8-32	6
91000	F1	fuse, 2amp	1	41000		screw, #6-32 x 1/4	12
50014	J1	jack, single phono	1	41003		screw, #8-32 x 3/8	6
50016	J2, 3	outlet, convenience	2	41016		screw, #4-40 x 1/4	10
97032	J4	jack, octal	1	41028		screw, #8-32 x 1	4
18050	R1	pot., 500KΩ, audio	1	42029		washer, rubber for fuseholder	1
10400	R2, 5, 10, 13, 14	res., 10KΩ, 1/2W, ±10% (brown, black, orange, silver)	5	42000		washer, lock, #3/8	1
10431	R3	res., 470KΩ, 1/2W, ±10% (yellow, violet, yellow, silver)	1	42001		washer, flat, #3/8	1
11543	R4	res., 1.8KΩ, 1/2W, ± 5% (brown, grey, red, gold)	1	42002		washer, lock, #6	10
11527	R6, 7	res., 100KΩ, 1/2W, ± 5% (brown, black, yellow, gold)	2	42007		washer, lock, #4	10
10412	R8, 9	res., 330KΩ, 1/2W, ±10% (orange, orange, yellow, silver)	2	42008		washer, lock, #8	8
11538	R11	res., 22KΩ, 1/2W, ± 5% (red, red, orange, gold)	1	42032		washer, flat, #8	4
14600	R12	res., 165Ω, 5W, ±5%	1	43000		lug, #6	1
10406	R15	res., 680Ω, 1/2W, ±10% (blue, grey, brown, silver)	1	43004		lug, #8	1
62004	S1	switch, slide, DPST	1	46000		grammet, 3/8	1
32005	T1	transformer, output	1	46006		feet, rubber	4
30019	T2	transformer, power	1	51006		plug, phono	1
54500	TB1	terminal board, 4 screw	1	51007		plug, octal	1
54001	TB2	terminal strip, 1 post right	1	57000		line cord	1
54003	TB3, 4	terminal strip, 2 post	2	58004		wire, hook-up	length
54002	TB4	terminal strip, 1 post right w/ground	1	58300		spaghetti	length
90034	V1	tube, 12AX7	1	58501		wire, bare, #22	length
90039	V2, 3	tube, EL84/7189/6BQ5	2	81165		chassis	1
90038	V4	tube, EZ81	1	81166		bottom plate	1
97800	XF1	fuseholder	1	97300		tube shield	1
97027	XV1	socket, 9 pin, top mount	1	66070		manual of instruction (wired)	1
				66319		manual of instruction (kit)	1

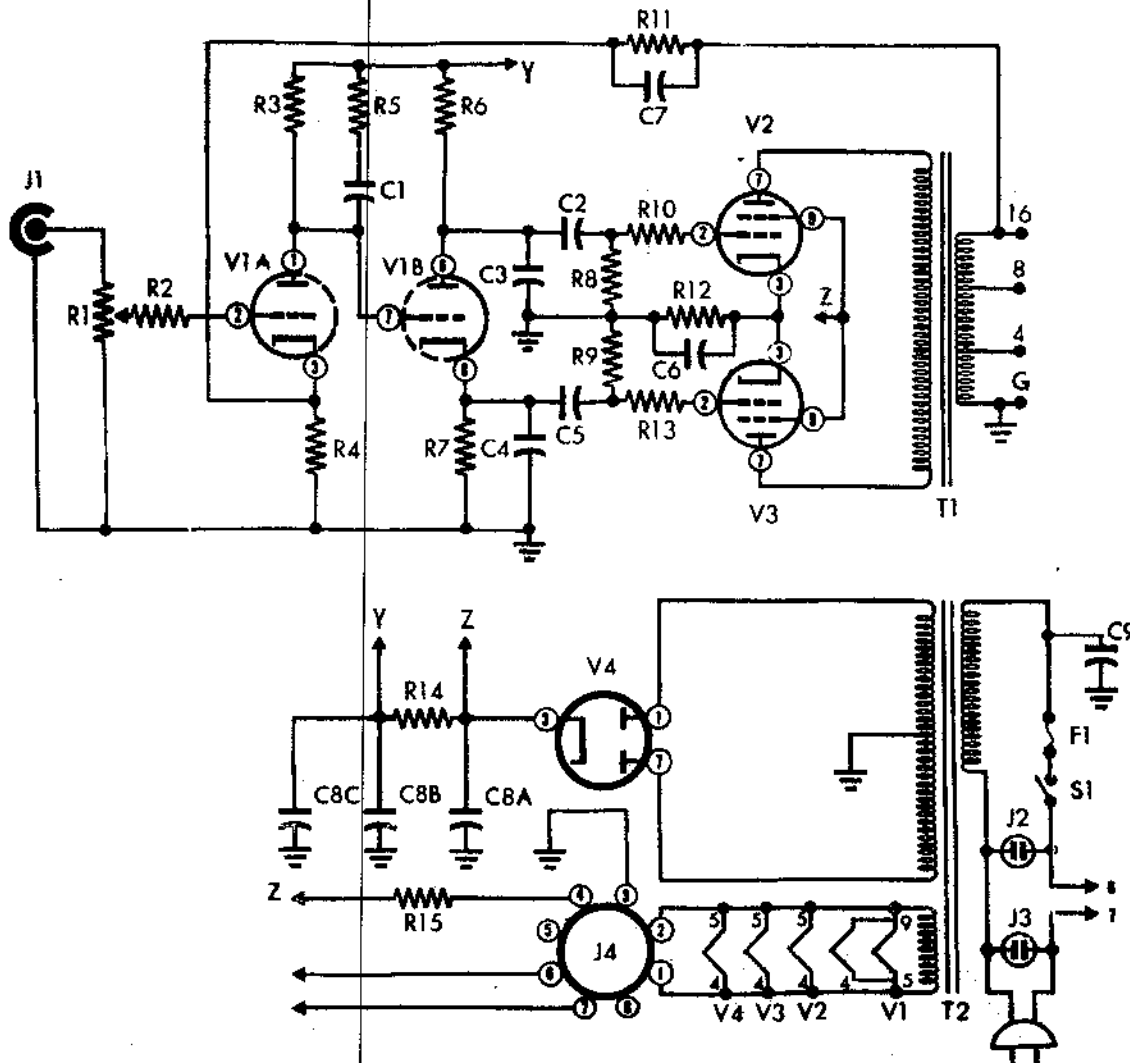

Sym. Description

- C1 cap., disc., 150 mmf, ±10%
- C2* cap., disc., .025 mfd
- C3 cap., disc., 200 mmf, ±10%
- C4 cap., disc., 200 mmf, ±10%
- C5 cap., disc., .025 mfd
- C6 cap., elec., 50 mfd - 25 V
- C7 cap., disc., 47 mmf, ±10%
- C8 cap., elec., 30-20-20 mfd - 450V
- C9 cap., paper, .03 mfd - 600 V
- F1 fuse, 2 amp
- J1 jack, single phono
- J2 outlet, convenience
- J3 outlet, convenience
- J4 jack, octal
- R1 pot., 500KΩ, audio
- R2 res., 10KΩ, 1/2W, ±10%
- R3 res., 470KΩ, 1/2W, ±10%
- R4 res., 1.8KΩ, 1/2W, ± 5%
- R5 res., 10KΩ, 1/2W, ±10%
- R6 res., 100KΩ, 1/2W, ± 5%
- R7 res., 100KΩ, 1/2W, ± 5%
- R8 res., 330KΩ, 1/2W, ±10%
- R9 res., 330KΩ, 1/2W, ±10%
- R10 res., 10KΩ, 1/2W, ±10%
- R11 res., 22KΩ, 1/2W, ± 5%
- R12 res., 165Ω, 5W, ± 5%
- R13 res., 10KΩ, 1/2W, ±10%
- R14 res., 10KΩ, 1/2W, ±10%
- R15 res., 680Ω, 1/2W, ±10%
- S1 switch, slide
- T1 transformer, output
- T2 transformer, power
- V1 tube, 12AX7
- V2 tube, EL84/6BQ5/7189
- V3 tube, EL84/6BQ5/7189
- V4 tube, EZ81

EICO

MODEL HF-14

14 WATT HIGH FIDELITY POWER AMPLIFIER

EICO



CAPACITOR COLOR CODES

RMA 3-507 COLOR CODE FOR MICA-DIELECTRIC CAPACITORS

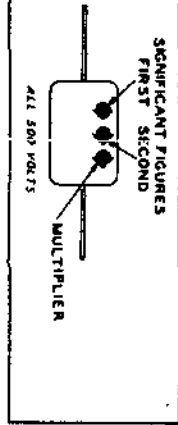

JAN 6-507 COLOR CODE FOR PAPER-DIELECTRIC CAPACITORS

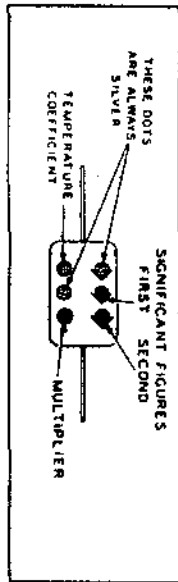

RESISTOR COLOR CODES

RMA COLOR CODE FOR FIXED COMPOSITION RESISTORS

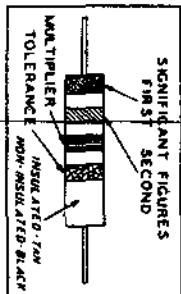

RADIAL TYPE

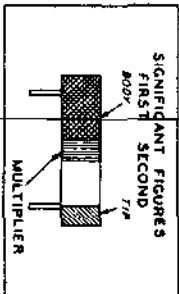

JAN COLOR CODE FOR FIXED COMPOSITION RESISTORS

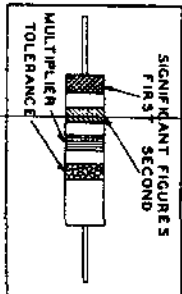

RADIAL TYPE NON-INSULATED

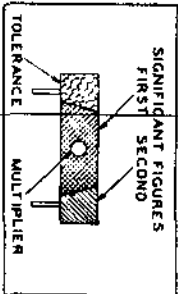

JAN 6-507 COLOR CODE FOR MICA-DIELECTRIC CAPACITORS

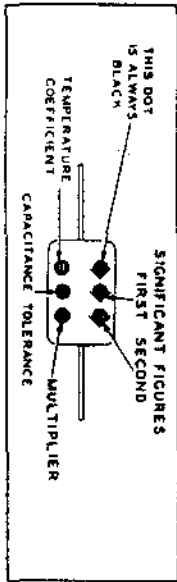

RMA 6-507 COLOR CODE FOR MICA-DIELECTRIC CAPACITORS

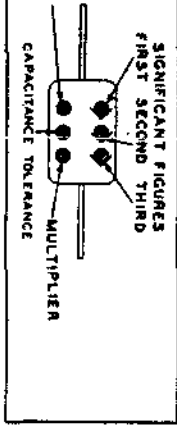

JAN COLOR CODE FOR FIXED CERAMIC-DIELECTRIC CAPACITORS

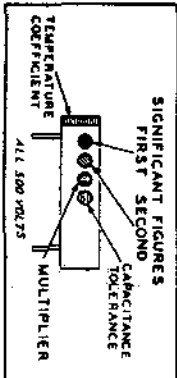

RADIAL TYPE NON-INSULATED

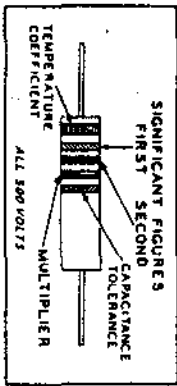

RMA COLOR CODE FOR TUBULAR CERAMIC-DIELECTRIC CAPACITORS

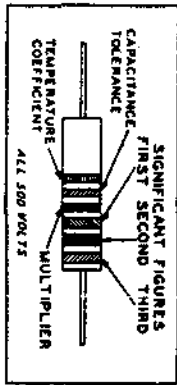

RMA: RADIO MANUFACTURERS ASSOCIATION
JAN: JOINT ARMY-NAVY

CAPACITORS

RESISTORS		CAPACITORS		VOLTAGE RATING		TEMPERATURE COEFFICIENT	
TOLERANCE	MULTIPLIER	SIGNIFICANT FIGURE	COLOR	RMA MICA AND CERAMIC-DIELECTRIC	JAN MICA AND PAPER-DIELECTRIC	JAN CERAMIC DIELECTRIC	
	1	0	BLACK	1	1	1	A
	10	1	BROWN	10	10	100	B
	100	2	RED	100	100	1000	C
	1000	3	ORANGE	1000	1000	10000	D
	10000	4	YELLOW	10000	10000	100000	E
	100000	5	GREEN	100000	100000	1000000	F
	1000000	6	BLUE	1000000	1000000	10000000	G
	10000000	7	VIOLET	10000000	10000000	100000000	
	100000000	8	GRAY	100000000	100000000	1000000000	
	1000000000	9	WHITE	1000000000	1000000000	10000000000	
	0.1		GOLD	0.1	0.1	0.1	
	0.01		SILVER	0.01	0.01	0.01	
	20		NO COLOR				

GENERAL INSTRUCTIONS

The section of the manual beginning with this page is the CONSTRUCTION section. All pages in this section have page numbers followed by "C" (1C, 2C, etc.). The INSTRUCTION section resumes on the pages following the CONSTRUCTION section. Note that the CONSTRUCTION section is located centrally in the book and may be removed without disrupting the INSTRUCTION section that both precedes it and follows it.

Care taken in the construction of this instrument will reward the constructor with many years of satisfactory service and greater confidence in his instrument. We urge you to not rush the construction, but to take all the time necessary for proper assembly and wiring.

Furthermore, we urge strongly that you follow the wire and parts layout shown in the pictorial diagrams as closely as possible. Very often wires are placed as shown for a good reason, and certainly the appearance of the completed instrument will be improved and the difficulty of finding a wiring error will be reduced by the following the wire and parts layout shown.

UNPACKING THE KIT: Unpack the kit carefully and check each part against the parts list including those parts that are mounted to the chassis. If you have trouble identifying any parts refer to the pictorial diagrams or the color code chart.

You will find that the value of a component will vary within the allowable circuit tolerance. For example, the $4.7K\Omega$, $\pm 10\%$ resistor may measure anywhere between $4.2K\Omega$ and $5.2K\Omega$. Tolerances on paper capacitors are substantially greater, and the tolerance for electrolytics is usually $+100\%$ and -50% .

CONSTRUCTION HINTS: USE THE BEST GRADE OF ROSIN CORE SOLDER ONLY, preferably one containing the new activated fluxes such as Kester "Resin-Five", Ersa "Multicore" or similar types. UNDER NO CIRCUMSTANCES USE ACID CORE SOLDER OR ACID FLUX since acid flux can cause serious corrosion. Before soldering make a certain of a good mechanical connection. Use a clean, freshly tinned soldering iron, no smaller than 100 watts, and place the solder on the joint (not on the iron) so that the solder is melted by the heat from the joint itself. Do not remove the soldering iron until the solder flows and check to see that the resulting joint is smooth and shiny when the solder has cooled. There are two extremes to be avoided; too little heat and too much heat. If too little heat is supplied, the joint will appear pitted and grey, indicating a rosin joint which is unsatisfactory. On the other hand, if too much heat is applied to a joint, the parts connected to it may either change value, lose their protective coating, or break down. If you are soldering close to a part, hold the lead between the part and the joint being sol-

dered with the tip of a pair of longnose pliers. The pliers will conduct the heat away and prevent the component from being unduly overheated. If for any reason it is necessary to resolder a joint, be sure to use new solder.

It should also be noted that the leads on resistors, capacitors, and transformers are often longer than required. These leads should be trimmed to the proper length when necessary. Do not cut any lead until you have determined the required length when the lead is routed as shown in the diagrams.

BASIC TOOLS REQUIRED: These basic tools are required for the construction of the amplifier.

1. Screwdriver - $3/16"$ to $1/4"$ blade
2. Screwdriver - $1/8"$ blade
3. Longnose pliers - 5 or 6"
4. Diagonal cutters
5. Soldering iron (100 watts), or soldergun, or pencil iron (35 watts)
6. Gas pliers
7. High quality rosin or equivalent synthetic flux core solder. Do not use acid or paste flux under any circumstances.

A set of spintites and a wire stripper are also very useful supplementary tools.

PARTS IDENTIFICATION: Please note that very many of the parts for which color coding is given may not be color coded, but have their values and ratings printed. The letter K is a multiplier (X1000) and on resistors or capacitors indicates that the printed numerical value must be multiplied by one thousand to obtain the value in ohms or micro-micro farads respectively. Note also that one microfarad (mf) is equal to one million; micro-microfarads (mmf). To aid in rapid identification, keep in mind that 5%, 10%, and 20% resistors are color coded whereas 1% resistors have their values printed; also that molded tubular capacitors may or may not be color coded, whereas disc capacitors and electrolytics will always have their values printed. Please note the following relationships between the units used to express resistance or capacity.

$$1,000,000 \text{ ohms } (\Omega) = 1000 \text{ kilohms } (K\Omega) = 1 \text{ megohm } (M\Omega)$$
$$1,000,000 \text{ micro-micro farads } (mmf) = 1 \text{ micro farad } (mf)$$

CONSTRUCTION PROCEDURE: The complete step-by-step mounting and wiring procedure follows. To keep the drawings uncrowded, unnecessary repetition of mounting or wiring details may be omitted. Note: The abbreviation (C) means connect but do not solder (until other leads have been connected). The abbreviation (S) means connect and solder.

Bend the ground lug tabs on the sockets toward the chassis to prevent accidental shorting to the socket pins.

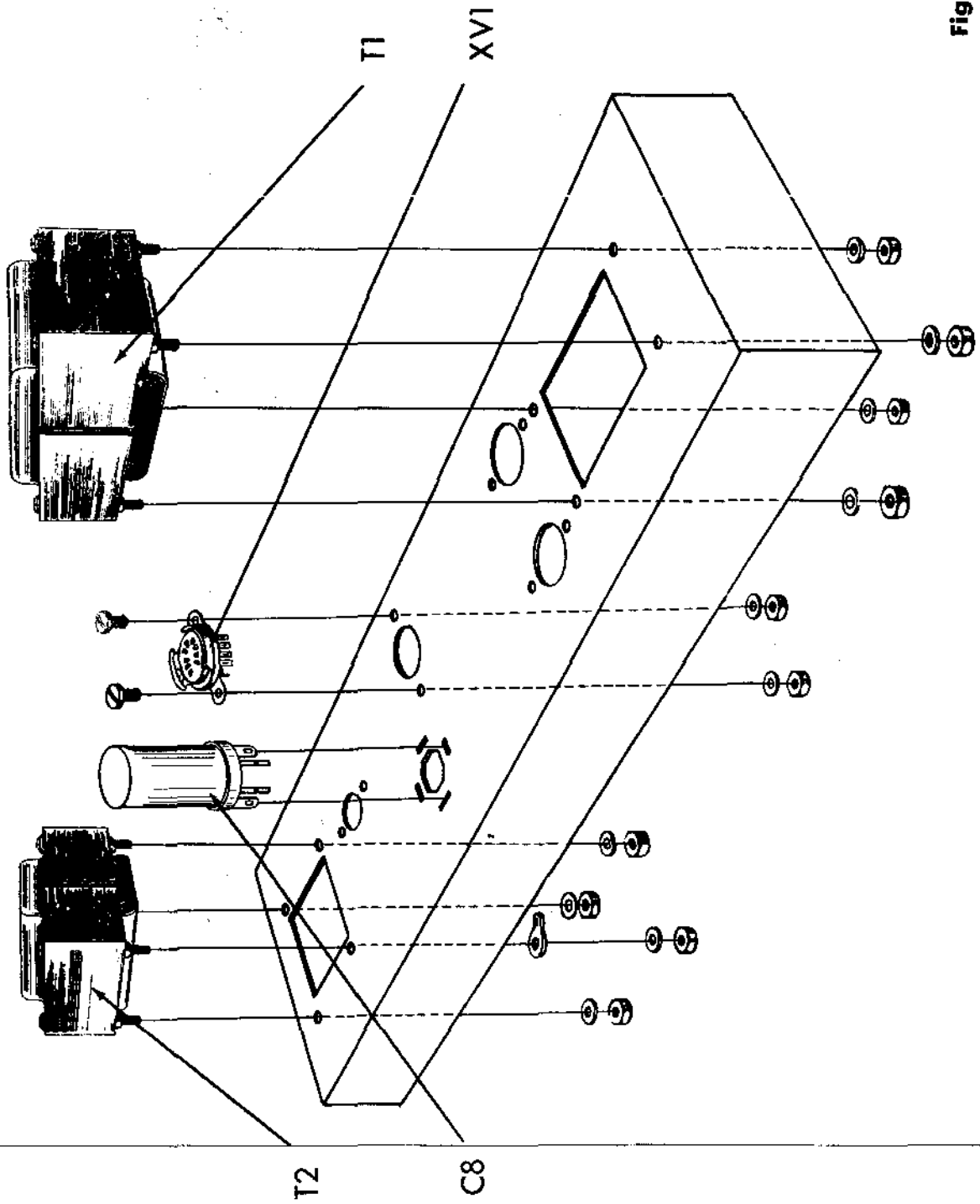

Fig. 1



TOP OF CHASSIS MOUNTING

When the leads on the transformers are too long, cut them to the size indicated in the steps below. In each case, after cutting the leads to the specified size, strip back 1/4" of the outer insulation so that the bare wire shows. Then tin the wire by dipping the stripped end into a solder pot, or melting solder onto the wire with a hot soldering iron.

1. () Fig. 1. On the power transformer T2, 30019, cut both red leads to 3", the red-yellow and white leads to 2 1/2" and the two green leads to 3 1/2". Do not cut the remaining leads. Mount the power transformer as shown, with the green leads closest to the side of the chassis (Fig. 4 & 5). Use four #8 lockwashers and four #8-32 hex nuts. Under one of the lockwashers, mount a #8 ground lug as shown in Fig. 4.

2. () Fig. 1. On the output transformer T1, 32005, cut the green lead to 3 1/2", the yellow lead to 1 1/2" and the blue lead to 4 1/2". Do not cut the remaining leads. Mount the output transformer as shown with the brown and the yellow leads closest to the rectangular hole in the side of the chassis (Fig. 4 & 5). Use four #8 lockwashers and four #8-32 hex nuts.

3. () Fig. 1. Mount the 9 pin miniature tube socket with shield support, XV1, as shown. Note direction in Fig. 4. Use two #4-40 screws, two #4 lockwashers and two #4-40 hex nuts.

4. () Fig. 1. Mount electrolytic can capacitor, C8, as shown. Note half-moon, square and triangle near lugs to determine direction of mounting (Fig. 4). Insert the mounting tabs into the slots in the chassis and twist the tabs somewhat less than a quarter turn. DO NOT twist the tabs excessively or they will shear off. Solder the tab without a hole to the chassis at its slot.

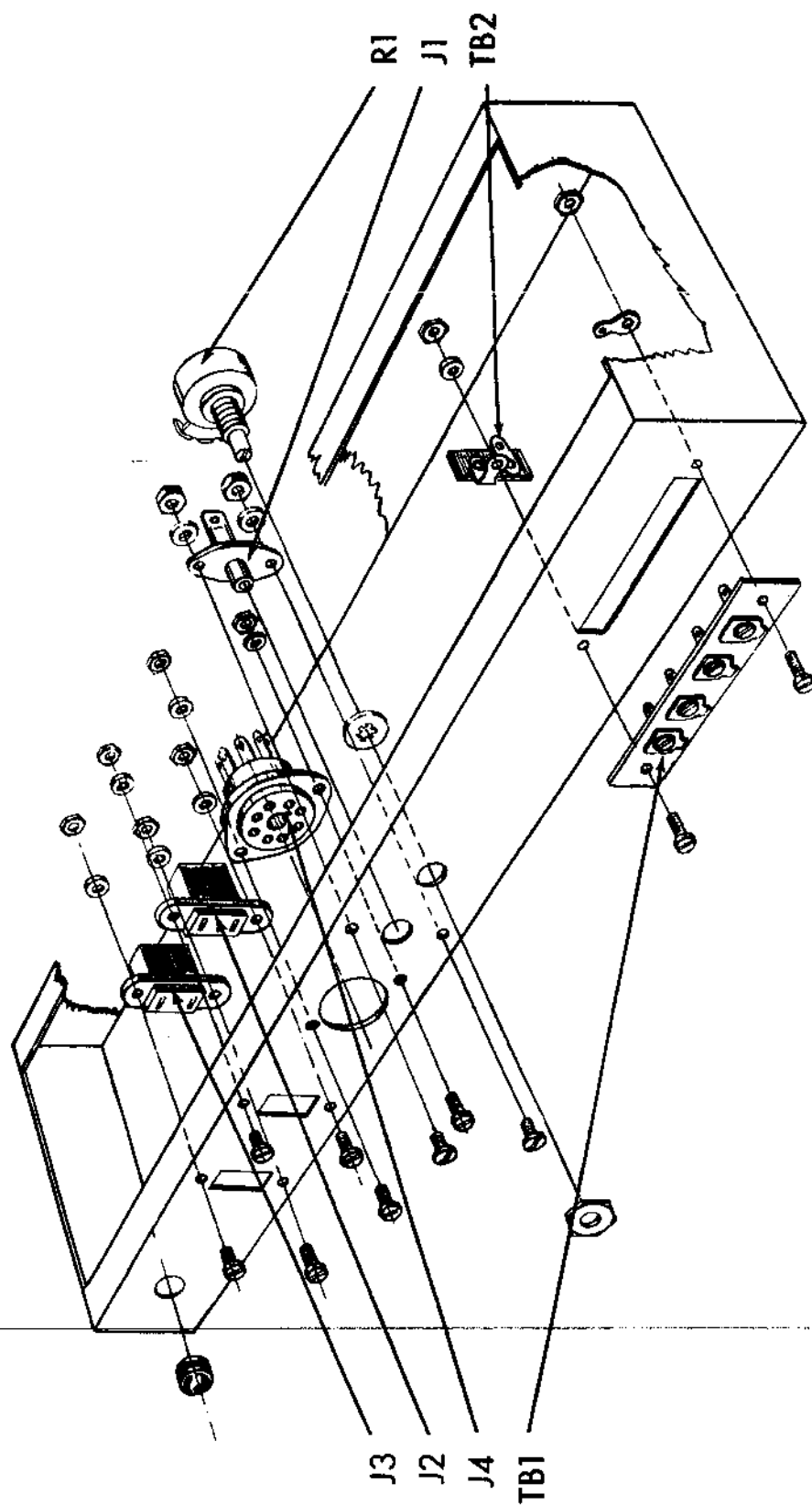

Fig. 2



REAR CHASSIS MOUNTING

1. () Fig. 2. Mount the four screw terminal board TB1, from the outside of the chassis as shown. Use two #6-32 screws and two #6-32 hex nut. Under one hex nut, mount a #6 ground lug. Under the second hex nut, mount a one post right terminal strip, TB2, and a #6 lockwasher.

2. () Fig. 2. Mount the potentiometer T1, as shown. Use one 3/8 lockwasher and one 3/8 hex nut.

3. () Fig. 2. Mount the input jack J1, as shown (Fig. 4). Use two #6-32 screws, two #6 lockwashers and two #6-32 hex nuts.

4. () Fig. 2. Mount the octal socket, J4, as shown. Note direction of key in Fig. 4. Use two #6-32 screws, two #6 lockwashers and two #6 hex nuts.

5. () Fig. 2. Mount convenience outlets J2 and J3, as shown. Use two #6-32 screws, two #6 lockwashers and two #6-32 hex nuts on each.

6. () Fig. 2. Push a 3/8" rubber grommet through the remaining hole at the rear of the chassis near convenience outlet J3.

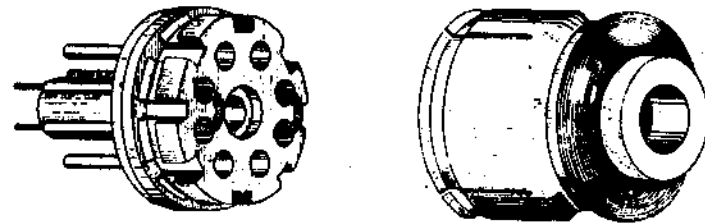

7. () Fig. 2A. Cut two 2" lengths of black hook-up wire. Strip 3/4" of insulation from both ends of each. This will leave 1/2" of insulation at the exact center of each wire. Bend each wire into a "U" shape. One will be used as a jumper between pins 2 and 3 of the octal plug and the other as a jumper between pins 6 and 7 of the octal plug.

8. () Fig. 2A. Push one end of one lead into pin 2 of the octal plug and the other end of the same lead into pin 3. When the lead ends have reached the ends of the pins, only the insulation will be visible at the rear of the plug.

9. () Fig. 2A. Similarly connect plug pins 6 and 7 with the other 2" lead.

10. () Fig. 2A. Form a puddle of solder at the tip of the soldering iron. Hold the plug with the pins down directly above the tip of the soldering iron. Dip each of the pin-ends into which wires have been inserted one at a time into the solder puddle and hold there for several seconds until the solder rises up into the pin by capillary action.

11. () Fig. 2A. Press the cap down over the octal plug. It may be left off if there is inadequate room at the desired location for mounting the chassis.

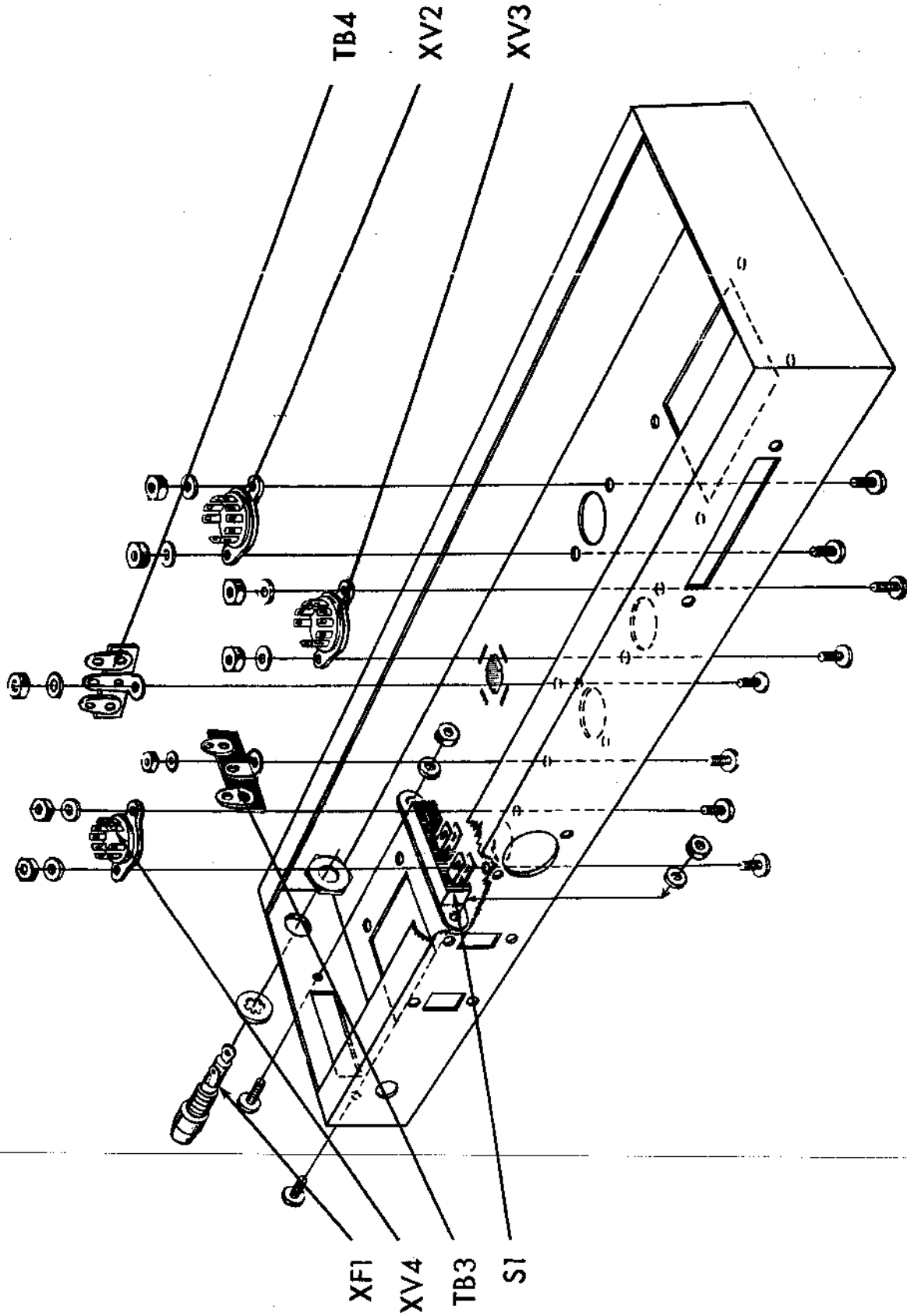

Fig. 3



FINAL CHASSIS ASSEMBLY

1. () Fig. 3. On the side of the chassis mount the slide switch S1, as shown. (Fig. 4). Use two #4-40 screws, two #4 lockwashers and two #4 hex nuts.

2. () Fig. 3. Mount fuseholder XF1 as shown. Use large rubber washer outside the chassis. Tighten to chassis with hex nut supplied. Do not tighten too much or holder will crack.

3. () Fig. 3. Mount the tube sockets XV2, XV3, and XV4 as shown (Fig. 4). Use two #4-40 screws, two #4 lockwashers and two #4-40 hex nuts on each.

4. () Fig. 3. Mount the two post terminal board TB3, and the two post terminal board, TB4 as shown. Use one #6-32 screw, one #6 lockwasher and one #6-32 hex nut on each.

8C

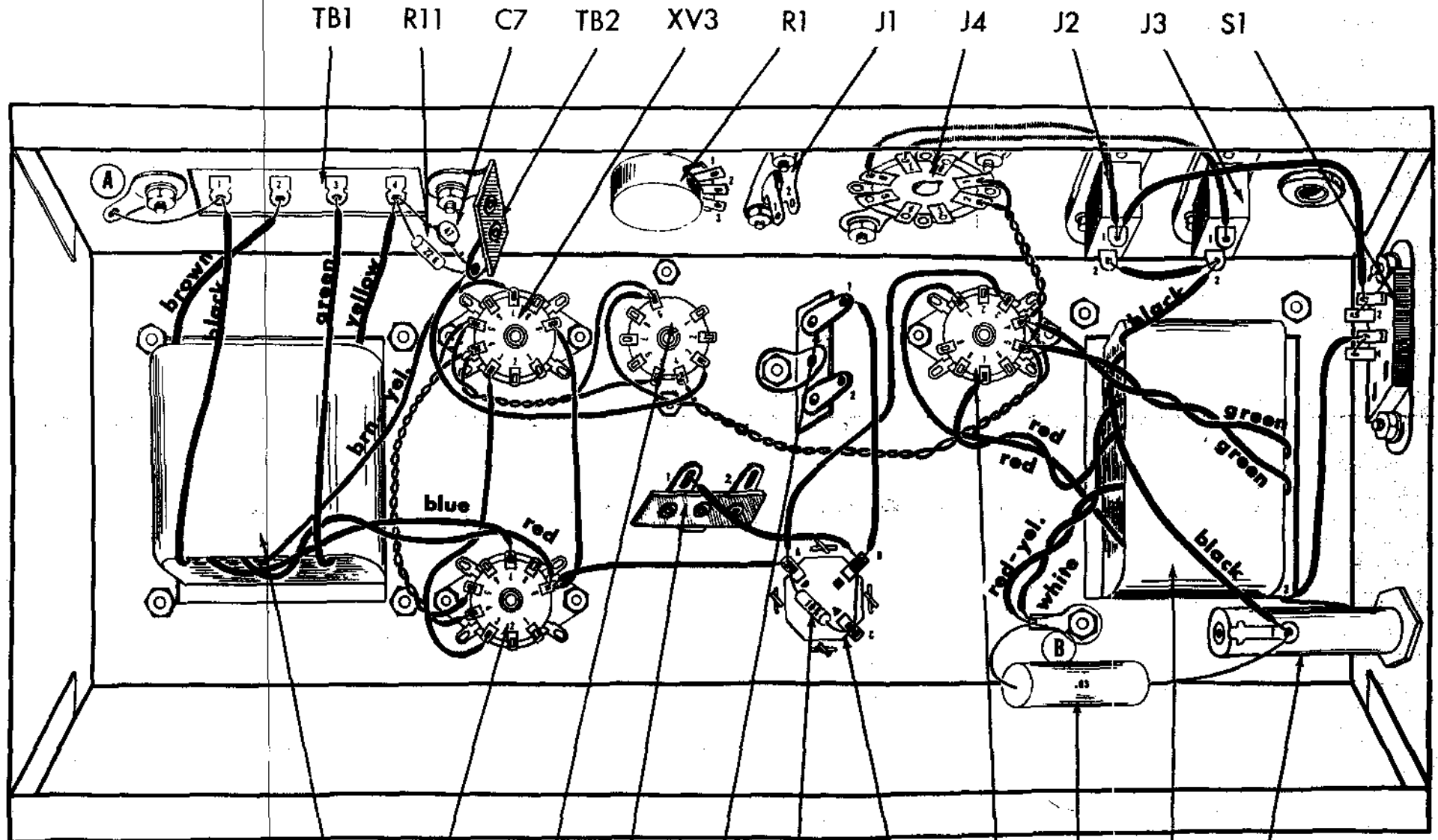

Fig. 4

T1 XV2 XV1 TB4 TB3 R14 C8 XV4 C9 T2 XF1

WIRING

1. (✓) Fig. 4. Connect a 1" piece of bare wire from TB1-1 (C) to ground lug "A" (S1).
2. (✓) Fig. 4. From output transformer T1, connect the black lead to TB1-1 (S2), the brown lead to TB1-2 (S1), the yellow lead to TB1-4 (C) and the brown-yellow lead to XV3-7 (S1). Twist the blue and red leads together. Connect the red lead to XV2-9 (C) and the blue lead to XV2-7 (S1). Connect the green lead to TB1-3 (S1).
3. (✓) Fig. 4. Cut both leads on a 22K Ω (red, red, orange, gold) 5% resistor, R11, to 1/2". Connect from TB1-4 (C) to TB2 (C).
4. (✓) Fig. 4. Cut both leads on a 47 mmf disc capacitor, C7, to 3/4". Connect from TB1-4 (S3) to TB2 (C).
5. (✓) Fig. 4. Connect one end of a 3" piece of yellow wire to XV2-4 (S1) and one end of a 3" piece of brown wire to XV2-5 (S1). Twist the two leads together and run along the chassis as shown. Connect the other end of the yellow wire to XV3-4 (C) and the other end of the brown wire to XV3-5 (C).
6. (✓) Fig. 4. Connect one end of a 3" piece of yellow wire to XV3-4 (S2) and one end of a 3 1/2" piece of brown wire to XV3-5 (S2). Twist the two leads together and run along the chassis as shown. Connect the other end of the brown wire to XV1-9 (C) and the other end of the yellow wire to XV1-5 (C).
7. (✓) Fig. 4. Connect a 1/2" piece of bare wire from XV1-5 (S2) to XV1-4 (C).
8. (✓) Fig. 4. Connect one end of a 5 1/2" piece of brown wire to XV1-9 (S2) and one end of a 5" piece of yellow wire to XV1-4 (S2). Twist the two leads together and run along the chassis as shown. Connect the other end of the brown wire to XV4-5 (C) and the other end of the yellow wire to XV4-4 (C).
9. (✓) Fig. 4. From the power transformer T2, twist the two green leads together. Connect one lead to XV4-4 (C) and the second green lead to XV4-5 (C).
10. (✓) Fig. 4. Connect one end of a 2" piece of brown wire to XV4-5 (S3) and one end of a 2" piece of yellow wire to XV4-4 (S3). Twist the leads together and connect to the other end of the brown wire to J4-2 (S1) and the other end of the yellow wire to J4-1 (S1).

11. (✓) Fig. 4. From the power transformer T2, twist the two red leads together. Connect the shorter red lead to XV4-7 (S1) and the longer red lead to XV4-1 (S1).
12. (✓) Fig. 4. Connect a 1 1/2" piece of black wire from J2-2 (S1) to J3-2 (C).
13. (✓) Fig. 4. Connect a 3/4" piece of bare wire from S1-1 (C) to S1-2 (S1).
14. (✓) Fig. 4. Connect a 3/4" piece of bare wire from S1-3 (C) to S1-4 (S1).
15. (✓) Fig. 4. Connect a 2" piece of black wire from S1-3 (S2) to XF1-2 (S1).
16. (✓) Fig. 4. Connect a 3 1/2" piece of black wire from J2-1 (C) to J4-6 (S1).
17. (✓) Fig. 4. Connect a 5" piece of black wire from J3-1 (C) to J4-7 (S1).
18. (✓) Fig. 4. Connect a 4" piece of black wire from S1-1 (S2) to J2-1 (S2).
19. (✓) Fig. 4. From the power transformer T2, twist the red-yellow and white leads together. Connect both leads to ground lug "B" (C).
20. (✓) Fig. 4. From the power transformer T2, connect one black lead to J3-2 (C) and the other black lead to XF1-1 (C).
21. (✓) Fig. 4. Cut both leads on a .03 mfd (orange, black, orange, black, blue) molded capacitor, C9, to 1". Connect from XF1-1 (S2) to ground lug "B" (S3).
22. (✓) Fig. 4. Connect a 2 1/2" piece of red wire from TB4-1 (C) to C8-B (C).
23. (✓) Fig. 4. Connect a 1" piece of bare wire from C8-B (C) to C8-C (C).
24. (✓) Fig. 4. Cut both leads on a 10K Ω (brown, black, orange, silver) resistor, R14, to 1/2". Connect from C8-A (C) to C8-C (S2).
25. (✓) Fig. 4. Connect a 4" piece of red wire from C8-A (C) to XV4-3 (C).
26. (✓) Fig. 4. Connect a 3" piece of red wire from C8-B (S3) to TB2-1 (C).
27. (✓) Fig. 4. Connect a 2 1/2" piece of red wire from XV2-9 (C) to XV3-9 (S1).
28. (✓) Fig. 4. Connect a 2 1/2" piece of red wire from C8-A (S3) to XV2-9 (S3).

10C

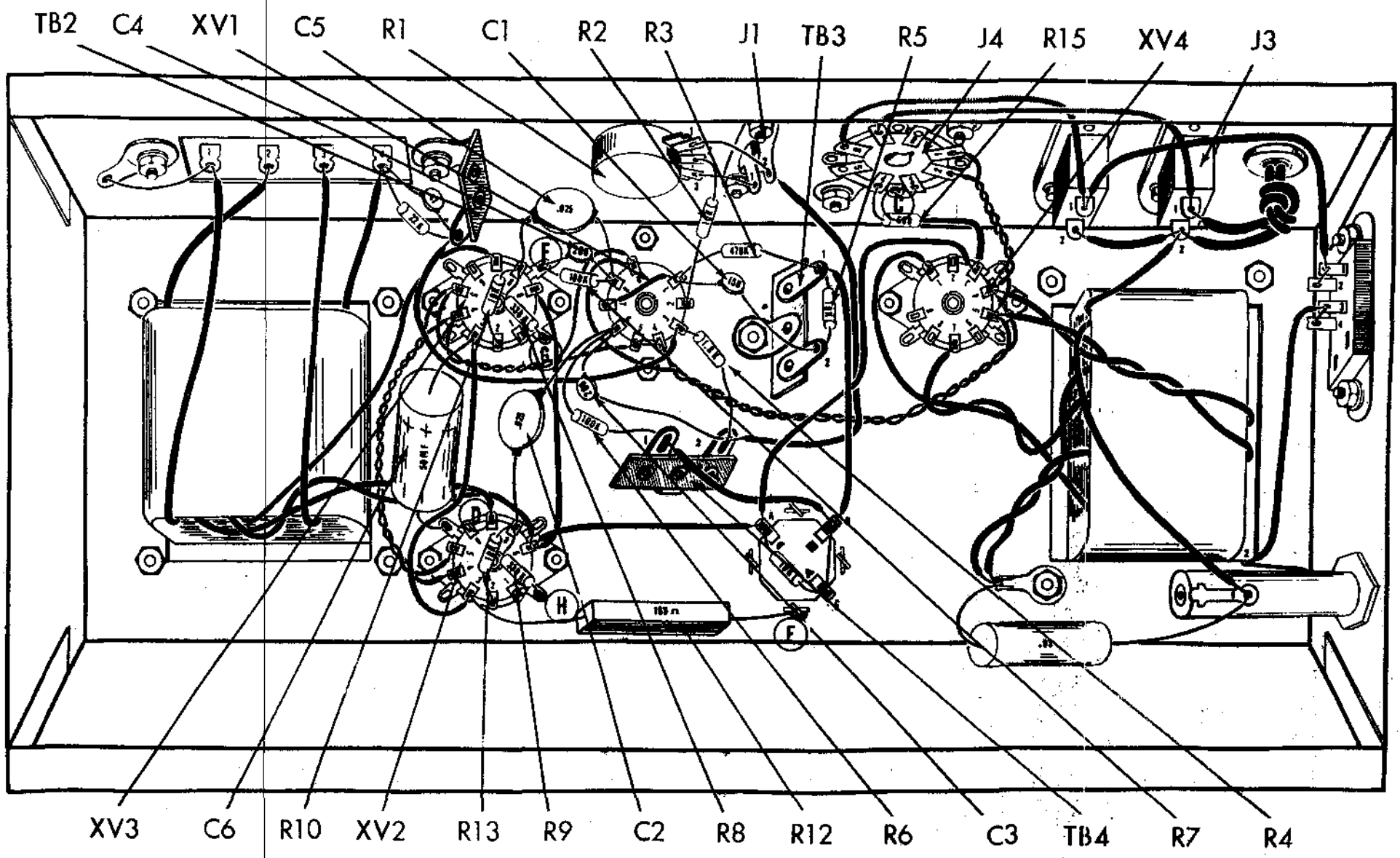

Fig. 5

1. (✓) Fig. 5. Connect a 3/4" piece of bare wire from J4-3 (S1) to ground lug "C" (S1) on socket J4.

2. (✓) Fig. 5. Cut both leads on a 680Ω (blue, grey, brown, silver) resistor, R15, to 3/4". Cover each lead with a 1/2" piece of spaghetti. Connect from XV4-3 (S2) to J4-4 (S1).

3. (✓) Fig. 5. Connect a 4 1/2" piece of black wire from TB2 (S3) to XV1-3 (C).

4. (✓) Fig. 5. Connect a 3" piece of black wire from XV3-3 (C) to XV2-3 (C).

5. (✓) Fig. 5. Cut both leads on a 50mfd electrolytic capacitor, C6, to 3/4". Cover both leads with a 1/2" piece of spaghetti. Connect the negative (-) lead to ground lug "D" (S1) at XV2 and the positive lead (+) to XV3-3 (S2).

6. (✓) Fig. 5. On the 165Ω wire wound resistor, R12, cut one lead to 3/4" and the second lead to 1 1/2". Cover the shorter lead with a 1/2" piece spaghetti and connect to XV2-3 (S2). Connect the longer lead to ground lug "E" (S1) on can capacitor, C8. Solder the ground lug "E" to the chassis at this point.

7. (✓) Fig. 5. Cut both leads on a 100KΩ (brown, black, yellow, gold) 5% resistor, R7, to 3/4". Cover each lead with a 1/2" piece spaghetti. Connect from XV1-8 (C) to ground lug "F" (C) at XV3.

8. (✓) Fig. 5. Cut both leads on a 200mfd disc capacitor, C4, to 3/4". Cover each lead with a 1/2" piece of spaghetti. Connect from XV1-8 (C) to ground lug "F" (S2) at XV3.

9. (✓) Fig. 5. Cut both leads on a .025mfd (25K or 25,000 mmf) disc capacitor, C5, to 3/4". Cover each lead with a 1/2" piece of spaghetti. Connect from XV1-8 (S3) to XV3-8 (C).

10. (✓) Fig. 5. Connect a 1" piece of bare wire covered with a 3/4" piece of spaghetti from XV1-1 (C) to XV1-7 (S1).

11. (✓) Fig. 5. Cut both leads on a 470KΩ (yellow, violet, yellow, silver) resistor, R3, to 1/2". Connect from XV1-1 (C) to TB3-1 (C).

12. (✓) Fig. 5. Cut both leads on a 150mfd disc capacitor, C1, to 3/4". Cover one lead with a 1/2" piece of spaghetti and connect to XV1-1 (S3). Connect the other lead to TB3-2 (C).

13. (✓) Fig. 5. Cut both leads on a 10KΩ (brown, black, orange, silver) resistor, R5, to 1/2". Connect from TB3-1 (S3) to TB3-2 (S2).

14. (✓) Fig. 5. Cut both leads on a 1.8KΩ (brown, grey, red, gold) resistor, R4, to 3/4". Connect from XV1-3 (S2) to TB4-2 (C).

15. (✓) Fig. 5. Cut both leads on a 200mfd disc capacitor, C3, to 1". Cover one lead with a 3/4" piece of spaghetti and connect to XV1-6 (C). Connect the other lead to TB4-2 (C).

16. (✓) Fig. 5. Cut both leads on a 100KΩ (brown, black, yellow, gold) 5% resistor, R6, to 1/2". Connect from XV1-6 (C) to TB4-1 (S2).

17. (✓) Fig. 5. Connect a 1" piece of bare wire from potentiometer R1-3 (S1) to J1-1 (S1).

18. (✓) Fig. 5. Cut one lead on a 10KΩ (brown, black, orange, silver) resistor, R2, to 1/2" and connect XV1-2 (S1). Cut the other lead to 3/4" and connect to potentiometer R1-2 (S1).

19. (✓) Fig. 5. Cut both leads on a .025mfd (25K or 25,000 mmf) disc capacitor, C2, to 1 1/4". Cover each lead with a 1" piece of spaghetti. Connect from XV1-6 (S3) to XV2-8 (C).

20. (✓) Fig. 5. Cut all leads on two 10KΩ (brown, black, orange, silver) resistors, R10 and R13, to 1/2". Connect R10 from XV3-8 (C) to XV3-2 (S1). Connect R13 from XV2-8 (C) to XV2-2 (S1).

21. (✓) Fig. 5. Cut all leads on two 330KΩ (orange, orange, yellow, silver) resistors, R8 and R9, to 1/2". Connect R8 from XV3-8 (S3) to ground lug "G" (S1) at XV3. Connect R9 from XV2-8 (S3) to ground lug "H" (S1) at XV2.

22. (✓) Fig. 5. Push the tinned solder leads from the line cord through the grommet on the rear apron of the chassis, next to J3. Tie a knot in the line cord 1 1/2" from the tinned solder leads so that the cord cannot pull through the grommet. Connect one solder lead to J3-2 (S3) and the second solder lead to J3-1 (S2).

23. (✓) Fig. 5. Connect a 4 1/2" piece of black wire from J1-2 (C) to TB4-2 (S3).

24. (✓) Fig. 5. Connect a 1 1/2" piece of black wire from J1-2 (S2) to R1-1 (S1).

17C

FINAL STEPS

You have now completed the assembly and wiring of your amplifier. When you have completed the following steps your amplifier will be ready for use.

1) To catch any wiring errors, it is suggested that the entire wiring be checked point-by-point against the wiring instructions (and preferably also against the schematic wiring diagram in order to become more familiar with the component layout and circuitry). While doing so, check for rosin joints, loose lumps of solder, poor lead dress, and accidental shorts or leakage paths arising from the flow of rosin between contacts (remove with a stiff brush dipped in carbon tetrachloride).

2) Clean socket XV1 with carbon tetrachloride using a stiff brush. It is also advisable to remove the tube and shield from XV1, and clean the socket and pins on top of the chassis.

3) Insert tubes V1 through V4 in their correct sockets and the fuse in the fuse holder. Place a shield over V1.

4) Insert the octal plug into octal socket J4.

5) **IMPORTANT: BE SURE TO MAKE THE FOLLOWING RESISTANCE CHECKS BEFORE CONNECTING TO THE AC LINE:** Check for a cold dc resistance of at least 3 ohms across the AC plug; check for a resistance of at least 85 ohms between ground and pins 1 and 7 of XV4; check for a resistance of at least 100K ohms between pin 3 of the rectifier tube V4 and ground. Allow sufficient time for the electrolytic capacitors to be charged by the ohmmeter battery in this last measurement. These measurements constitute a reasonable check of the power supply components and wiring before applying power. If you fail to obtain these resistance values, do not proceed to the next step until the cause is discovered and the condition remedied. If the measurements are satisfactory, proceed to step 6.

6) Press a speed nut in place over each hole on the bottom flange of the chassis (see Fig. 6).

7) If the amplifier is not going to be fastened to some surface, insert the rubber feet in the openings provided in the bottom plate and mount the bottom plate of the chassis, using 3 #8-32 x 3/8" screws. Do not use the 1" long screws for

this purpose. If the amplifier is to be fastened to a surface, the feet will not be used and the bottom plate will be required as a template before it is attached to the amplifier.

8) Read the **MECHANICAL INSTALLATION** and **ELECTRICAL INSTALLATION** sections of the instruction book carefully, and install and connect the amplifier according to the information given.

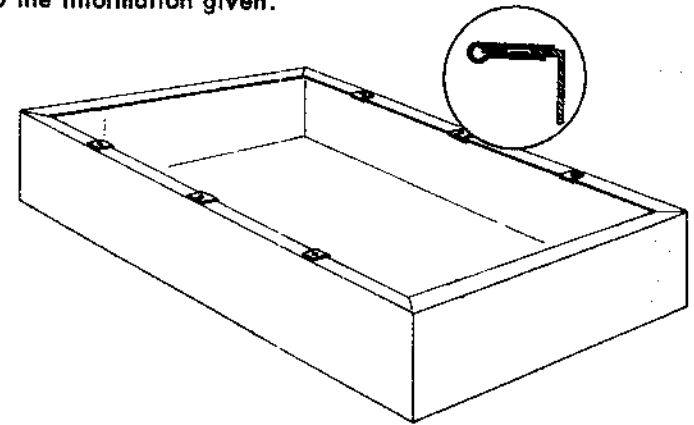

Fig. 6

SERVICE

If you are still having difficulty, write to our service department listing all possible indications that might be helpful. If desired, you may return the instrument to our factory where it will be placed in operating condition for \$5.00 plus the cost of parts replaced due to their being damaged in the course of construction. This service policy applies only to completed instruments constructed in accordance with the instructions as stated in the manual. Instruments that are not completed or instruments that are modified will not be accepted for repair. Instruments that show evidence of acid core solder or paste fluxes will be returned not repaired. **NOTE:** Before returning this unit, be sure all parts are securely mounted. Attach a tag to the instrument, giving your home address and the trouble with the unit. Pack very carefully in a rugged container, using sufficient packing material (cotton, shredded newspaper, or excelsior), to make the unit completely immovable within the container. The original shipping carton is satisfactory, providing the original inserts are used or sufficient packing material is inserted to keep the instrument immovable. Ship by prepaid Railway Express, if possible, to the Electronic Instrument Co., Inc., 33-00 Northern Blvd. L.I.C. 1, New York. Return shipment will be made by express collect. Note that the carrier cannot be held liable for damages in transit if packing, **IN HIS OPINION**, is insufficient.