

H. H. SCOTT, INC.
111 Powder Mill Road
Maynard, Mass.

SERVICE BULLETIN

FOR

MODEL 222B STEREO AMPLIFIER

SPECIFICATIONS

Maximum power output each channel (music waveforms)	15 watts
Maximum power output each channel (steady state)	13 watts
Maximum total harmonic distortion at rated output	0.8 %
Frequency response	*20 to 20 kc. \pm 0.5 db.
Power bandwidth at rated distortion (IHFM standards)	*25 to 20 kc.
Intermodulation Distortion (CCIF method)	0.3 %
Signal for rated output -- NAB (NARTB) tape at 1 kc.	3.0 mv.
Signal for rated output -- RIAA equalization at 1 kc.	3.0 mv. (MAG LOW)
Signal for rated output -- RIAA equalization at 1 kc.	9.0 mv. (MAG HIGH)
Signal for rated output -- Tuner, Extra, and Playback	0.50 volts
Hum and noise -- high level inputs	80 db. below rated power
Hum and noise -- low level inputs	10 microvolts equivalent
Scratch filter	Above 5 kc.
Treble boost and Treble cut (at 10 kc.)	15 db. \pm 2 db.
Bass boost and cut (at 50 cycles)	15 db. \pm 2 db.

(These characteristics are measured at a line voltage of 117 volts rms and line frequency of 60 cycles per second. No significant changes of characteristics should be experienced for normal variations of line voltages or a line frequency of 50 cycles per second).

Input impedance -- low level inputs (MAG LOW)	47 k. ohms
Input impedance -- low level inputs (MAG HIGH)	150 k. ohms
Input impedance -- high level inputs	500 k. ohms
Minimum recommended load resistance on tape outputs	200 k. ohms
Maximum recommended cable capacitance on tape outputs	200 mmfds.
Range of line voltage and frequency	105-125 volts, 50-60 cycles
Power consumption -- 117 volts at 60 cps (A.C. only)	170 watts

- * All H. H. Scott amplifiers and preamplifiers incorporate a sharp cutoff filter (12 db. or sharper per octave) which becomes fully operative below 20 cycles. This is designed to prevent overload of the output stage and the loudspeaker due to subsonic rumble frequencies and record eccentricity. This means that the full power of the amplifier can be concentrated into the audible range.

GENERAL SERVICE NOTES

1. Check the tubes, particularly those in the power output stage and the rectifier every year. If the tubes are outside the manufacturer's ratings or show gas, they should be replaced. Gassy tubes may damage other components of the circuit.
2. When the amplifier is being checked yearly, clean the tubes of dust so that they may radiate their heat more effectively.
3. If at any time the hum or noise increases noticeably, check the power tubes. This symptom is often an indication of gassy tubes.
4. If the amplifier blows fuses frequently, check the line voltage. If it rises above 125 volts, drop the line voltage by means of an auto-transformer or place a voltage regulator transformer between the amplifier and the line. If the line voltage is correct, check the amplifier itself. Do not use fuse sizes other than the fuse size specified.

SERVICE PROCEDURE - (Should only be performed by qualified, experienced service agency, employing adequate test instruments)

1. Equipment necessary:

Oscilloscope, audio oscillator, VTVM (AC and DC), 16 ohm resistive load of adequate wattage (some wirewound resistors have considerable residual inductance and these should be avoided), an adjustable 400 cycle null (schematic for making one of these simple, but extremely useful devices can be obtained by writing to the Engineering Department). For laboratory measurements, a wave analyzer may be necessary.

Instruments wired from kits generally have distortion far too high for servicing precision electronic components.

2. Bias adjustment:

Remove bottom plate of amplifier. Place a DC voltmeter across the 1.2 k resistor (R 201 on schematic) and adjust bias control until meter reads 38.5 volts. Bias control is located between the electrolytic and the power transformer.

3. D.C. Balance:

The control for each amplifier output stage is located between the output tubes for that stage. These controls should be adjusted when the output tubes age appreciably or are replaced. To set these controls use the following procedure:

- (a) Connect the 16 ohm resistor across the output terminal of the amplifier under test.
- (b) Connect the oscilloscope across the resistor, and turn the horizontal selector of the scope to "LINE".
- (c) Remove the phase inverter tube (6BL8) of the amplifier under test.
- (d) Adjust the proper D.C. balance control for a minimum 120 cycle response on the scope.
- (e) Repeat the entire procedure for the other amplifier output stage.

4. A.C. Balance:

These controls should be adjusted when the output and phase inverter tubes age appreciably or are replaced. They are located to the side of each phase inverter (6BL8). The simplest method of adjustment is as follows:

- (a) Connect 16 ohm resistor across output terminal of Channel A amplifier.
- (b) Connect a lead across the resistor and feeding into the null (the 400 cycle null referred to above).
- (c) From the null feed to the VTVM.
- (d) Feed into the amplifier the audio oscillator tuned to 400 cycles.
- (e) Make sure that the oscillator and the null are tuned to exactly the same frequency.
- (f) Adjust the AC balance control for minimum reading on the VTVM.
- (g) Repeat the entire procedure for Channel B.

An alternate method would be to use a distortion or wave analyzer in place of the null and the VTVM. Then the AC balance control would be adjusted for minimum second harmonic distortion on the analyzer. It is very important to emphasize that in the use of this method, distortion analyzers made from kits have far too much distortion themselves to be employed.

- 5. Other routine tests can be performed to insure that the unit meets or exceeds the specifications outlined previously. Only use parts and tubes specified by H. H. Scott. The use of non-standard parts or tubes will preclude obtaining the performance stated in the specifications.

If you have any further questions, write to:

Technical Services Dept.
 H. H. Scott, Inc.
 111 Powder Mill Road
 Maynard, Massachusetts

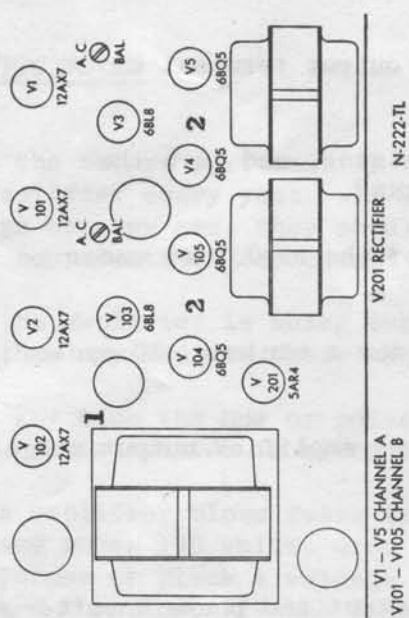
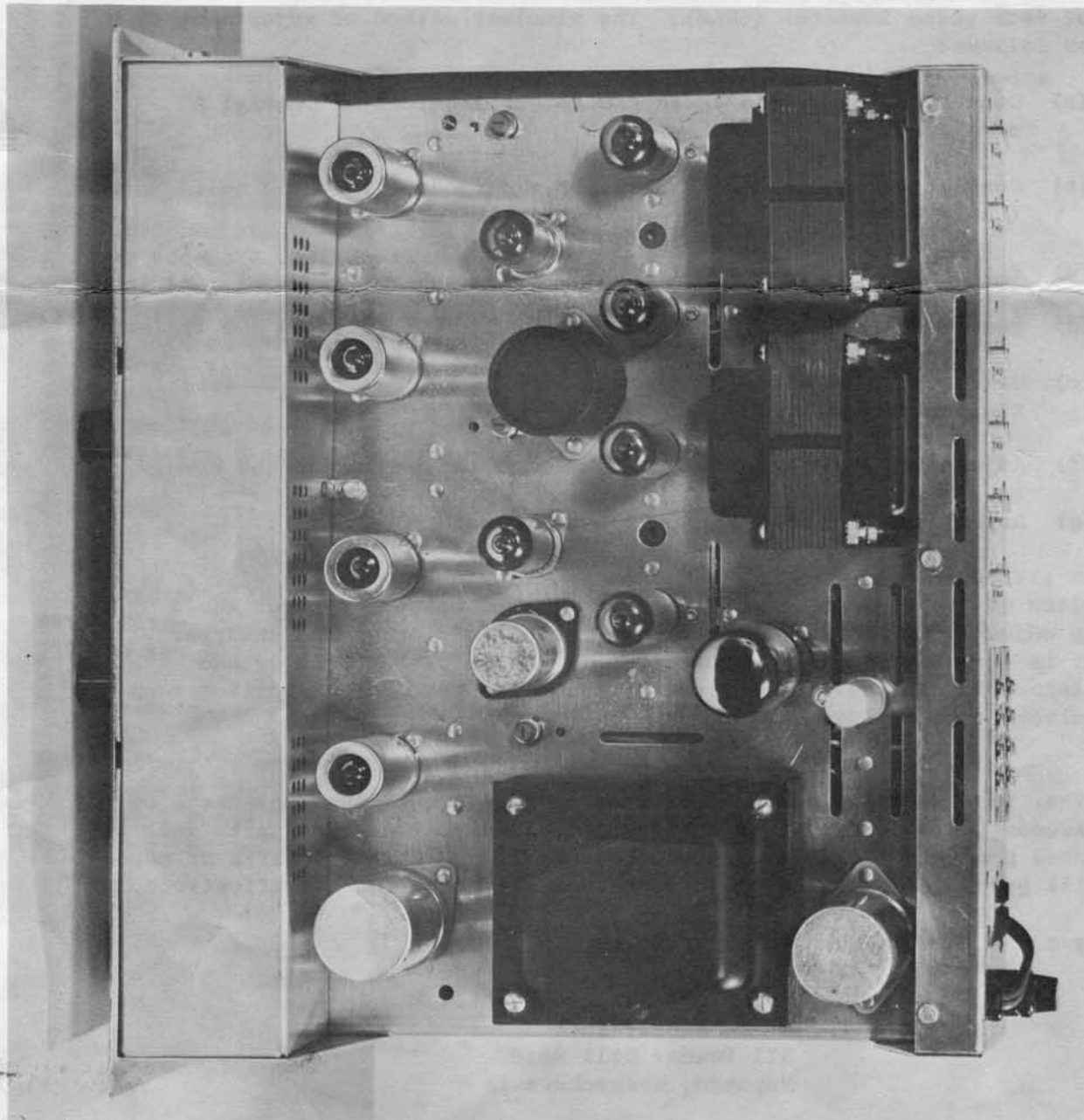

1. Bias Control
2. D.C. Balance Controls

STEREO SELECTOR SWITCH

POSITION	FUNCTION
1	BALANCE A
2	BALANCE B
3	MONOPHONIC RECORDS
4	STEREO
5	REVERSE STEREO
6	CHANNEL A
7	CHANNEL B

INPUT SELECTOR SWITCH

POSITION	FUNCTION
1	PHONO
2	TUNER
3	EXTRA

EQUALIZATION SWITCH

POSITION	FUNCTION
1	RIAA-NABTS-ORTHO
2	NABTS-TAPE

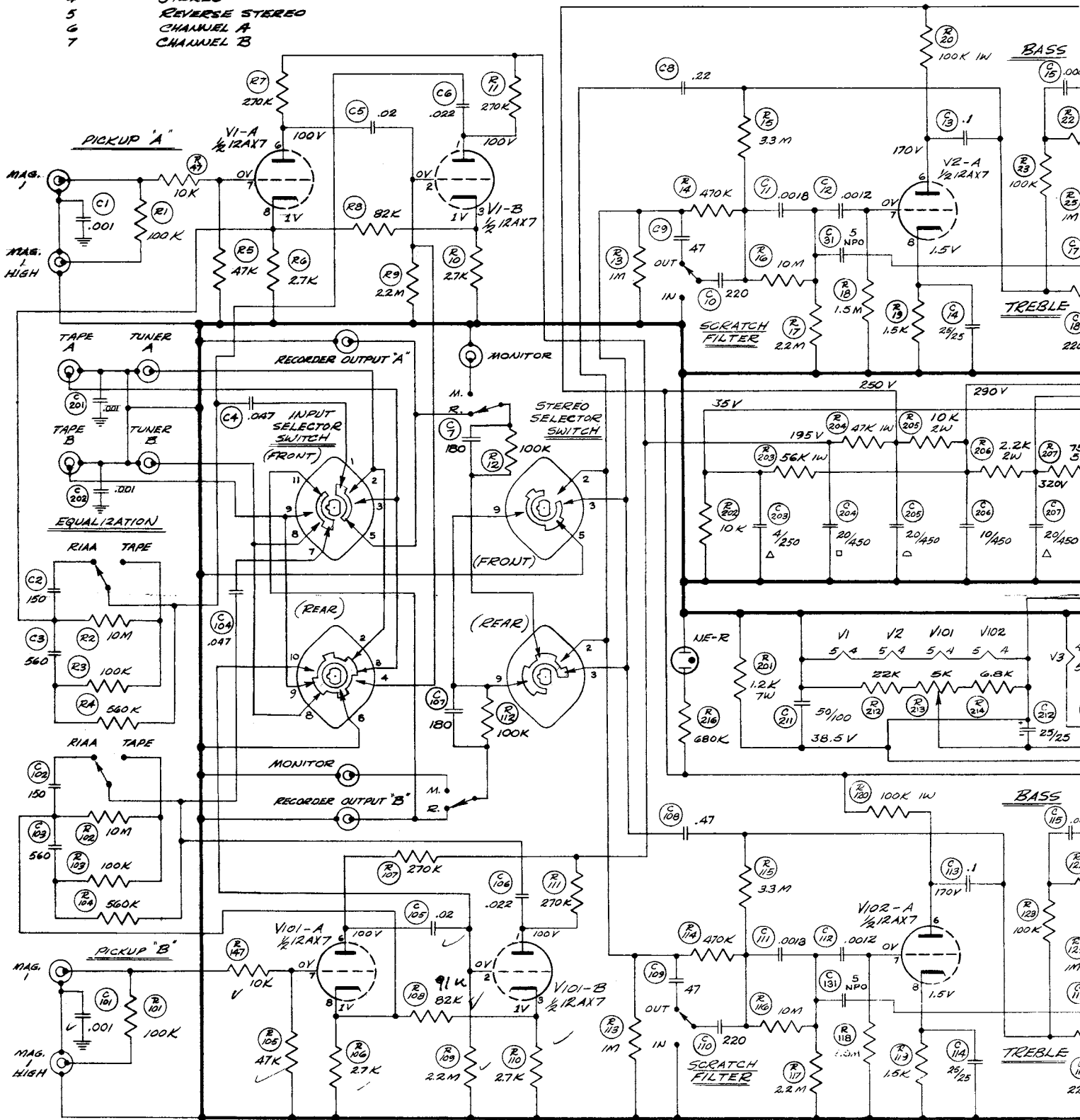

THE FOLLOWING CONTROLS IN CHANNEL "A" ARE MECHANICALLY GANGED WITH IDENTICAL CONTROLS IN CHANNEL "B"...

- 1. INPUT SELECTOR
- 2. EQUALIZATION
- 3. SCRATCH FILTER
- 4. LOUDNESS-VOLUME
- 5. LOUDNESS CH. POWER SWITCH

REVISIONS

1	DMG. NO. CHANGE FROM 222-C1-7 TO 222-B-C1-0
2	4/22/60. RUM. D
3	ECO #776. ADD
4	ECO #482/RB
5	6/3/60 W.L.
6	ECO #557. ADD
7	R-49. RYAS
8	2/22/61. H.C. 5

R 49, 149, 216
C 32, 132, 213

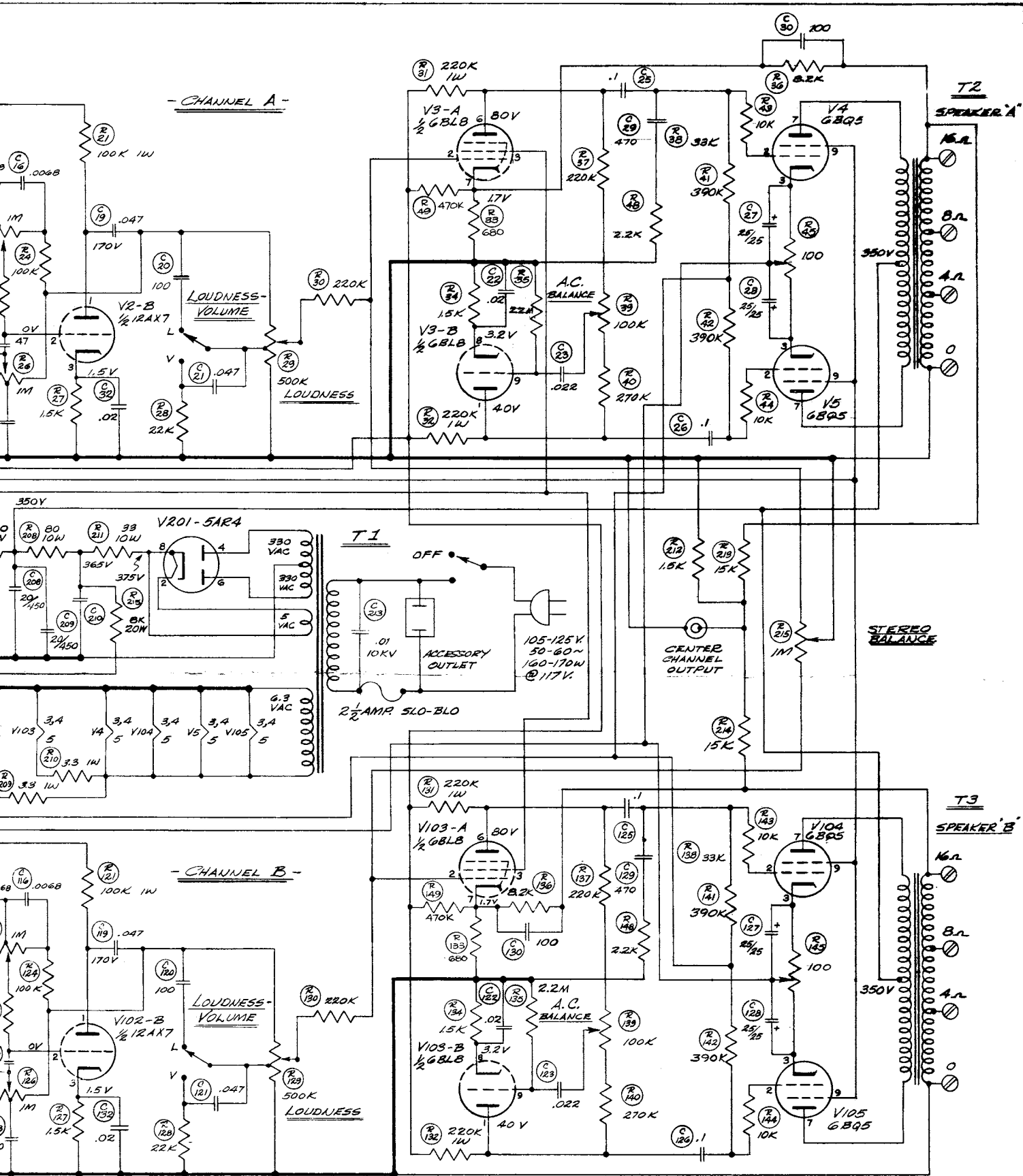

TYPE 222B STEREO AMPLIFIER

1. ALL VOLTAGES D.C. $\pm 15\%$ MEASURED WITH V.T.V.M.
2. NO INPUT SIGNAL \hat{E} 117 VOLT LINE
3. SWITCHES SHOWN IN MAXIMUM C.C.W. POSITION.

SCALE: NONE	DEC. 31, 1950
222B CIRCUIT DIAGRAM	
H. H. SCOTT, INC. MAYNARD, MASS., U.S.A.	
DR. R. MARTIN	ENG. <i>[Signature]</i>
CH:	PROD:
DWG. NO. D-222B-C1 REV 3	